

REVISION DATA				
SYM	ECN	DESCRIPTION	DATE	APPROVED

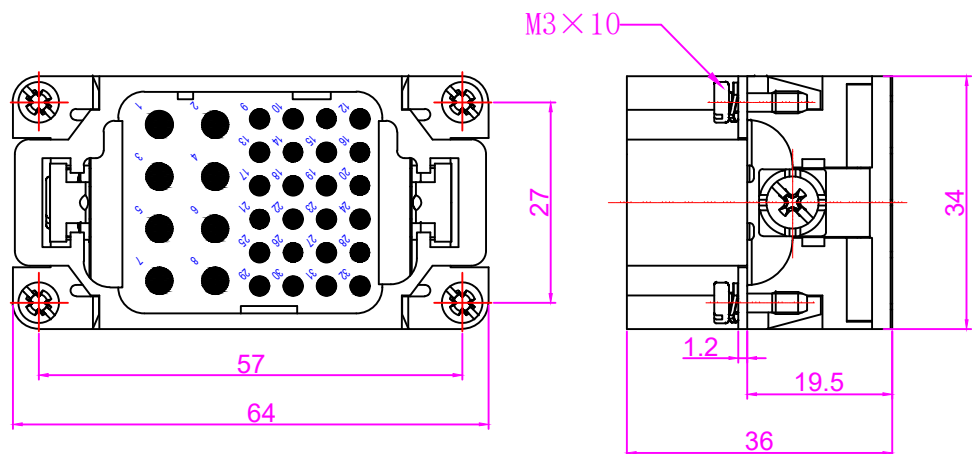

技术参数:
 插芯:
 插针数: 8/24+PE
 电源:
 额定电流: 16A
 工作电压: 230/400V
 额定脉冲电压: 4KV
 污染等级: 3
 信号:
 额定电流: 10A
 工作电压: 160V
 额定脉冲电压: 2.5KV
 污染等级: 3
 依据UL/CSA的额定电压: 600V/300V
 绝缘阻抗: $\geq 10^{10} \Omega$
 材料: 聚碳酸酯
 温度范围: $-40^{\circ}\text{C} \sim +125^{\circ}\text{C}$
 依据UL94的阻燃等级: V0
 可插拔次数: ≥ 500

Specifications:
 Inserts:
 Number of contacts: 8/24+PE
 Power arera:
 Rated current: 16A
 Rated voltage: 230/400V
 Rated impulse voltage: 4KV
 Pollution degree: 3
 Signal area:
 Rated current: 10A
 Rated voltage: 160V
 Rated impulse voltage: 2.5KV
 Pollution degree: 3
 Rated voltage acc. to UL/CSA: 600/300V
 Insulation resistance: $\geq 10^{10} \Omega$
 Material: Polycarbonate
 Limiting temperatures: $-40^{\circ}\text{C} \sim +125^{\circ}\text{C}$
 Flammability acc. to (UL94): V0
 Mechanical working life -mating cycles: ≥ 500

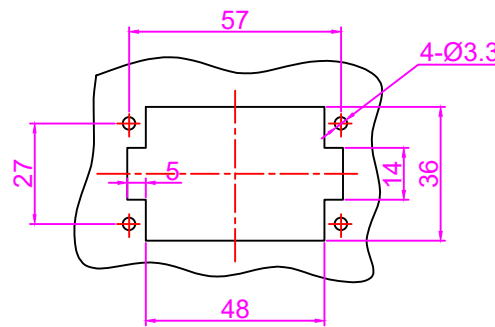

面板开孔图
Panel cut

插针:
 接线方式: 冷压连接
 材料: 铜合金
 表面处理: 镀银 镀金
 接触电阻:
 电源: $\leq 3 \Omega$
 信号: $\leq 1 \Omega$
 线径范围:
 电源: 0.5~4.0mm² (AWG20-12)
 信号: 0.14~2.5mm² (AWG26-14)

Contacts:
 Terminal: screw terminal
 Material: Brass
 Surfac: hard-silver plated/Gold plated
 Contact resistance:
 Power arera: $\leq 3m \Omega$
 Signal area: $\leq 1m \Omega$
 Crimp terminal
 Power arera:
 Wire gauge--mm²: 0.5~4.0mm²
 Wire gauge--AWG: 20-12
 Signal area:
 Wire gauge--mm²: 0.14~2.5mm²
 Wire gauge--AWG: 26-14

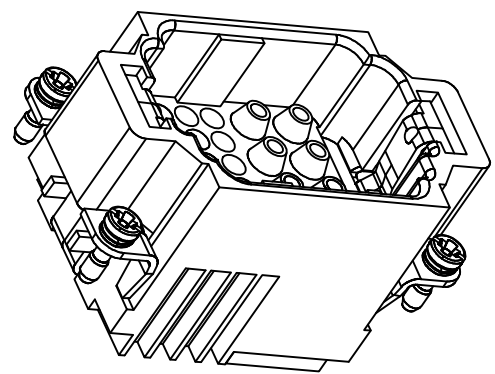

Tolerance		SIGNATURE	DATE	Units	mm
0~ ≤ 20	± 0.15	DRAW		Size	A4
20~ ≤ 50	± 0.25	DESIGN		Scale	
50~ ≤ 80	± 0.35	CHECK		Sheet	
80~ ≤ 120	± 0.50	APPROVE		Proj.	

宁波欧科瑞连接器有限公司
NINGBO OUKERUI CONNECTOR CO.,LTD.

PART NAME: HZW-HK-8/24-M			
Drawing NO.			REV
Material			A