

REVISION DATA				
SYM	ECN	DESCRIPTION	DATE	APPROVED

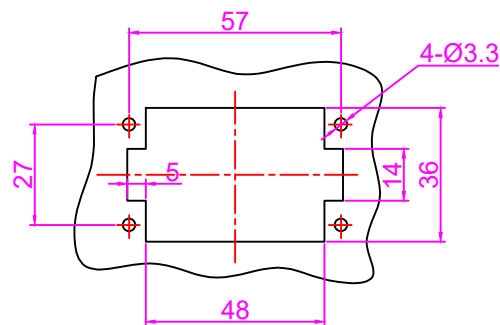

面板开孔图  
Panel cut

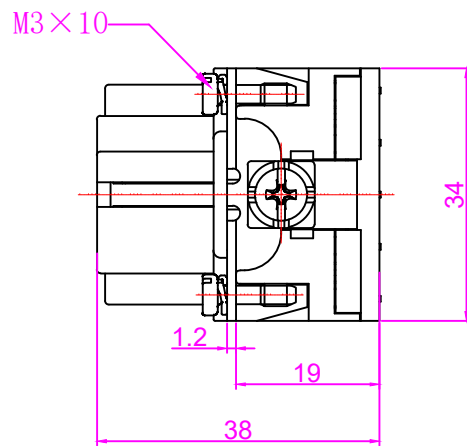
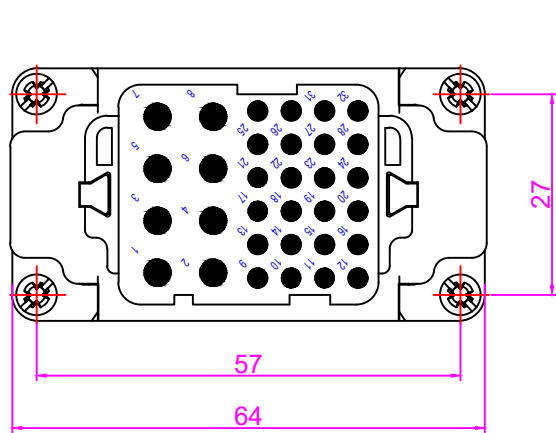
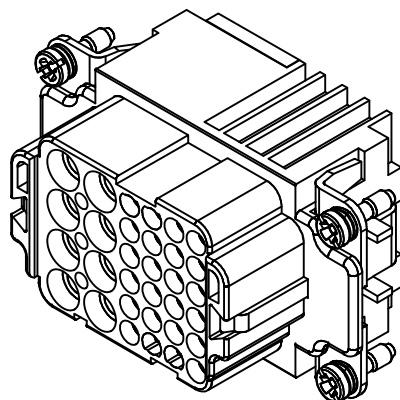

技术参数:  
 插芯:  
 插针数: 8/24+PE  
 电源:  
 额定电流: 16A  
 工作电压: 230/400V  
 额定脉冲电压: 4KV  
 污染等级: 3  
 信号:  
 额定电流: 10A  
 工作电压: 160V  
 额定脉冲电压: 2.5KV  
 污染等级: 3  
 依据UL/CSA的额定电压: 600V/300V  
 绝缘阻抗:  $\geq 10^{10} \Omega$   
 材料: 聚碳酸酯  
 温度范围:  $-40^{\circ}\text{C} \sim +125^{\circ}\text{C}$   
 依据UL94的阻燃等级: V0  
 可插拔次数:  $\geq 500$

插针:  
 接线方式: 冷压连接  
 材料: 铜合金  
 表面处理: 镀银 镀金  
 接触电阻:  
 电源:  $\leq 3 \Omega$   
 信号:  $\leq 1 \Omega$   
 线径范围:  
 电源:  $0.5 \sim 4.0 \text{mm}^2$  (AWG20-12)  
 信号:  $0.14 \sim 2.5 \text{mm}^2$  (AWG26-14)

Specifications:  
 Inserts:  
 Number of contacts: 8/24+PE  
 Power arera:  
 Rated current: 16A  
 Rated voltage: 230/400V  
 Rated impulse voltage: 4KV  
 Pollution degree: 3  
 Signal area:  
 Rated current: 10A  
 Rated voltage: 160V  
 Rated impulse voltage: 2.5KV  
 Pollution degree: 3  
 Rated voltage acc. to UL/CSA: 600/300V  
 Insulation resistance:  $\geq 10^{10} \Omega$   
 Material: Polycarbonate  
 Limiting temperatures:  $-40^{\circ}\text{C} \sim +125^{\circ}\text{C}$   
 Flammability acc. to (UL94): V0  
 Mechanical working life -mating cycles:  $\geq 500$

Contacts:  
 Terminal: screw terminal  
 Material: Brass  
 Surfac: hard-silver plated/Gold plated  
 Contact resistance:  
 Power arera:  $\leq 3 \text{m} \Omega$   
 Signal area:  $\leq 1 \text{m} \Omega$   
 Crimp terminal  
 Power arera:  
 Wire gauge-- $\text{mm}^2$ :  $0.5 \sim 4.0 \text{mm}^2$   
 Wire gauge--AWG: 20-12  
 Signal area:  
 Wire gauge-- $\text{mm}^2$ :  $0.14 \sim 2.5 \text{mm}^2$   
 Wire gauge--AWG: 26-14

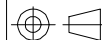
Tolerance		SIGNATURE	DATE	Units	mm	 宁波欧科瑞连接器有限公司 NINGBO OUKERUI CONNECTOR CO.,LTD.
0~ $\leq 20$	$\pm 0.15$	DRAW		Size	A4	
20~ $\leq 50$	$\pm 0.25$	DESIGN		Scale		
50~ $\leq 80$	$\pm 0.35$	CHECK		Sheet		
80~ $\leq 120$	$\pm 0.50$	APPROVE		Proj.		PART NAME: HZW-HK-8/24-F Drawing NO. <span style="float: right;">REV</span> Material <span style="float: right;">A</span>